

PIPER CHEROKEE SIX / LANCE SERVICE MANUAL

COMPONENT	LUBRICANT	FREQUENCY
1. OLEO STRUT FILLER POINT (See Spec. Instr. 4)	MIL-PRF-5606	AS REQUIRED
2. STEERING BELLCRANK PIVOT POINT (See Spec. Instr. 1)	MIL-PRF-7870	100 HRS
3. SHIMMY DAMPENER PIVOT POINT (See Spec. Instr. 1)	MIL-PRF-7870	100 HRS
4. TORQUE LINK ASSEMBLY (See Spec. Instr. 2)	MIL-PRF-7870	100 HRS
5. NOSE WHEEL BEARINGS (See Spec. Instr. 3)	MOBIL-GREASE 28 MIL-PRF-81322E	100 HRS
6. NOSE GEAR STEERING ROD END BEARINGS (See Spec. Instr. 1)	MIL-PRF-7870	100 HRS
7. EXPOSED OLEO STRUT (See Spec. Instr. 2)	DRY LUBRICANT MS-122AD	100 HRS

CAUTION: DO NOT USE HYDRAULIC FLUID WITH A CASTOR OIL OR ESTER BASE.

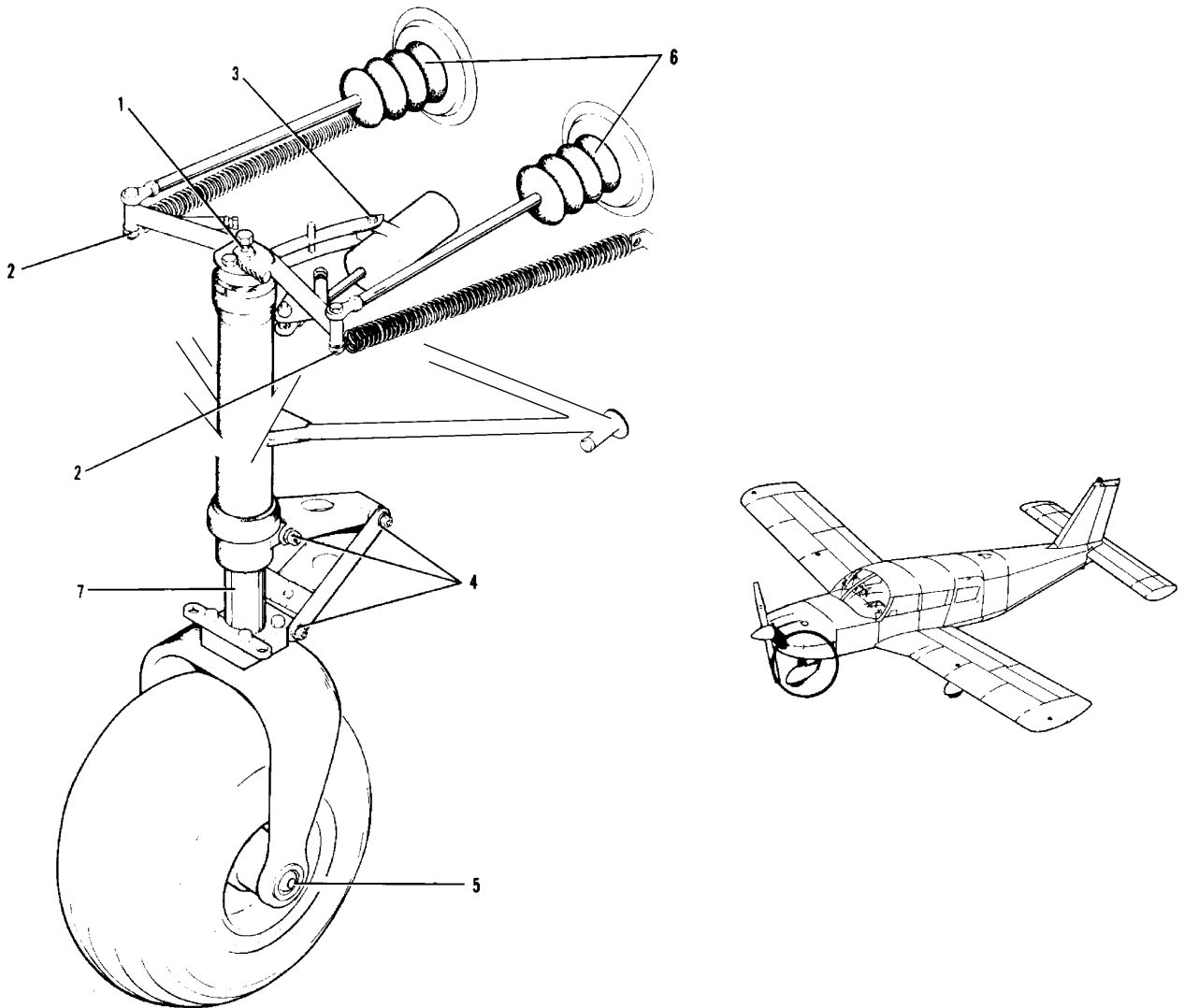

Figure 2-10. Lubrication Chart (Landing Gear, Nose) PA-32-260 and-300